



CAUTION: THESE SERVICING INSTRUCTIONS ARE FOR USE BY QUALIFIED SERVICE PERSONNEL ONLY. TO AVOID ELECTRIC SHOCK DO NOT PERFORM ANY SERVICING OTHER THAN THAT CONTAINED IN THE OPERATING INSTRUCTIONS UNLESS YOU ARE QUALIFIED TO DO SO. REFER ALL SERVICING TO QUALIFIED RANE WARRANTY SERVICE STATIONS.

Disassembly Procedure

CAUTION: WAIT ABOUT 15 MINUTES AFTER THE AMPLIFIER HAS BEEN POWERED DOWN BEFORE BEGINNING DISASSEMBLY PROCEDURE, TO ALLOW THE POWER SUPPLY CAPACITORS TO DISCHARGE.

1. Remove the bottom cover: 4 ea. #6 x 3/8" phillips screws on the side rails and 10 ea. #6 x 1/4" phillips screws on the edges of the bottom cover.
 2. To remove a module (PCB card):
 - a. Remove the input/output plate on the rear panel by removing 7 phillips screws and 12 ea. #8 tapping screws from the Euroblocks.
 - b. Remove the 7 phillips screws on the front panel just below the Level controls.
 - c. Remove the 8 ea. #6/32x3/4" machine screws from the left and right edges of the heatsink mounting flange. Now the entire heatsink/module assembly is free to slide to the rear—this will provide the clearance necessary to remove any of the six amp modules.
 - d. To remove a module, first de-solder the wires running to the adjacent card. Be sure to note the location of all wires for later reassembly (A to A, B to B). Then remove 7 ea. of the #4-40 machine screws holding the output, driver and bias transistors to the heatsink. Now pull firmly straight up to disengage the module from the connector—use a rocking motion to ease removal, as the connector is very tight.
- NOTE: Be sure that all of the transistor sil pads (insulators) stay on the heatsink—some of these may stick on the transistor and be inadvertently lost or thrown away with the defective component. New pads should be used whenever possible.*
3. Module replacement: Factory supplied modules are pre-tuned and ready for installation. If you have made repairs on a module, be sure that ALL diodes are measured and replaced as necessary prior to installation of the module.
 - a. Be sure that all sil pads (insulators) are in place on the heatsink.
 - b. *Be sure the nylon shoulder washers are in place on transistors Q2, Q4 and Q8 (TO-220 cases). Install the #4-40 screws in these and snug up only: Do not over-tighten these driver screws as this may damage the thin shoulder washers and cause a short.*
 - c. Install the remaining 4 ea. #4-40 screws on the output and *tighten these firmly to ensure proper heat transfer to the heatsink.*
 - d. Resolder the black & white wires. Be careful to connect them properly.
 - e. Slide heatsink assembly forward so that all LEDs are properly aligned in the front panel holes. Install and tighten the 8 heatsink mounting screws.
 - f. Replace the seven screws on the front panel.
 - g. Replace the input/output plate and bottom cover (don't forget the four screws holding the bottom cover to the side rails).
 4. Power supply repairs.
 - a. Power supply PCB: Do not attempt removal of this card. Instead, remove amplifier modules #1 and #2 as necessary to allow clear access to the foil side of the power supply PCB; then replace any defective components by de-soldering.
 - b. Transformer removal: The transformer is held in place by one 1/4" bolt securing the transformer to the flat mounting plate. Removal of this bolt allows transformer replacement. Pull all transformer spade plugs from the power PCB and lift the transformer out of the chassis . To replace the transformer, reverse the above procedure. Reconnect all transformer spade plugs as shown on the power board assembly diagram.

MA 6S AMP CARD

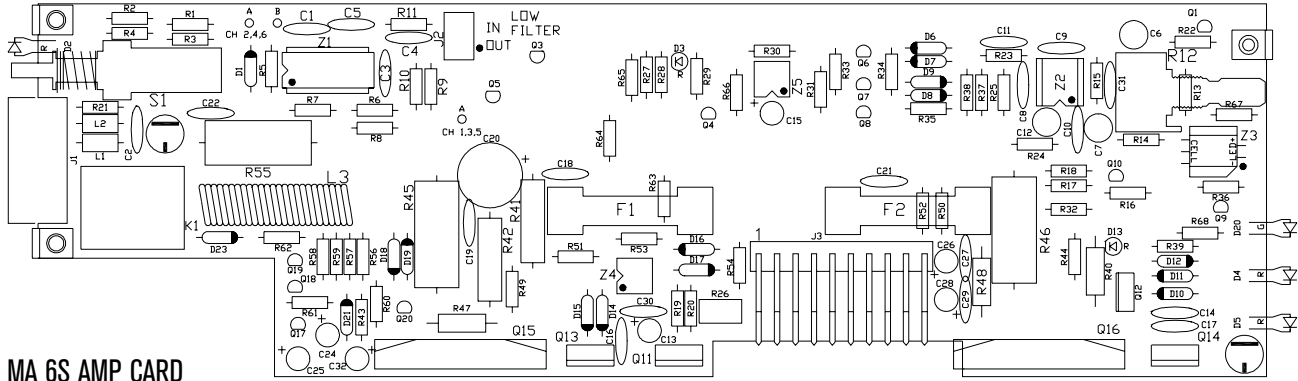

MA 6S POWER SUPPLY

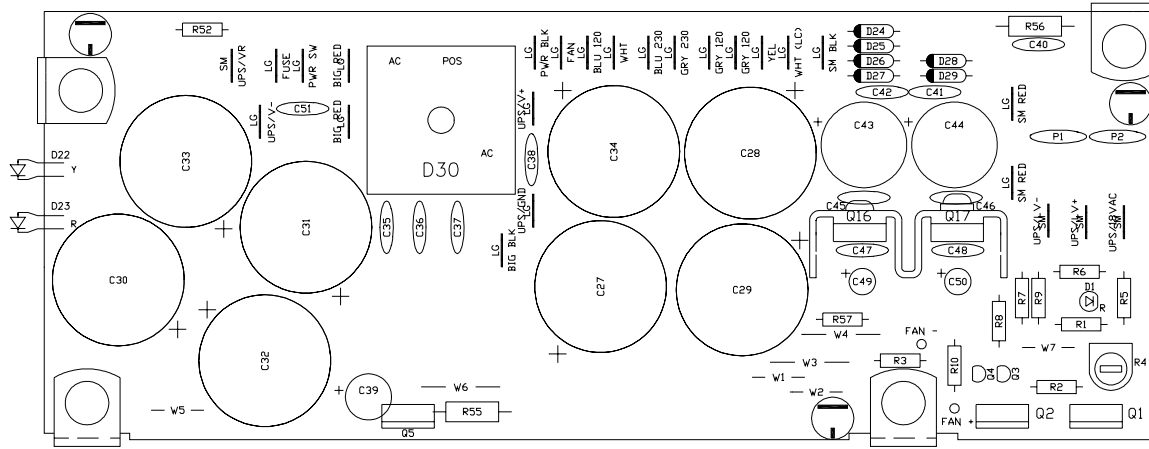

MA 6S BUS CONNECTOR

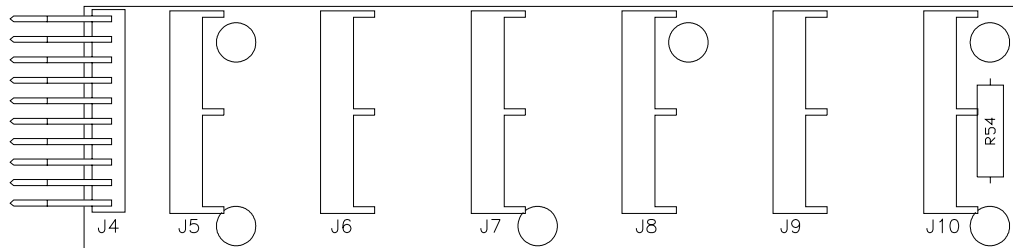

101552 SHEET 2 OF 2 DES: AMP MA 6S
ACTION: NO CHANGE TO PART, NEW DOC# SKH 9FEB98

101557 SHEET 2 OF 2 DES: PWR MA 6S
ACTION: NO CHANGE TO PART, NEW DOC# SKH 9FEB98

101561 SHEET 2 OF 2 DES: BUS MA 6S
ACTION: NO CHANGE TO PART, NEW DOC# SKH 9FEB98

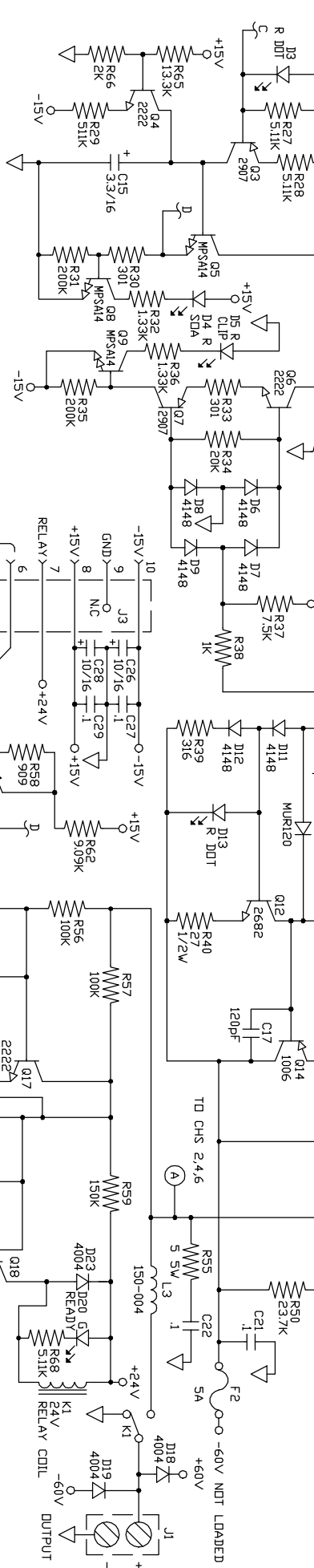
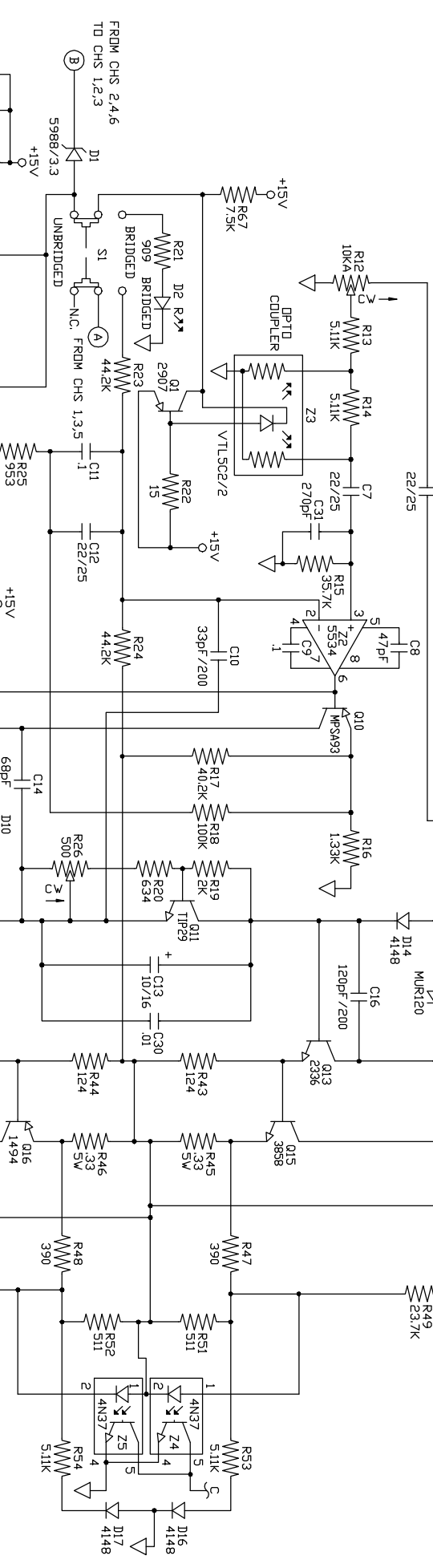
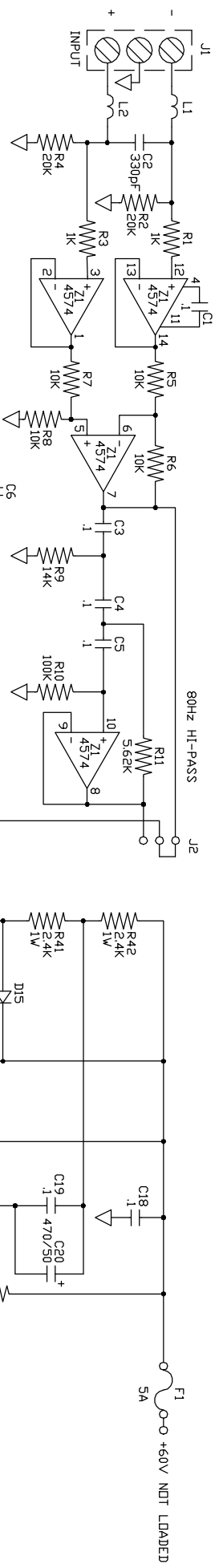

- NOTES (UNLESS OTHERWISE SPECIFIED)**
1. ALL RES 1% METAL FILM
 2. ALL FERRITE BEADS 2.5 TURN
 3. POWER SUPPLY CONNECTIONS
- SING DUAL 8 NEG SUP
 QUAD 4 4

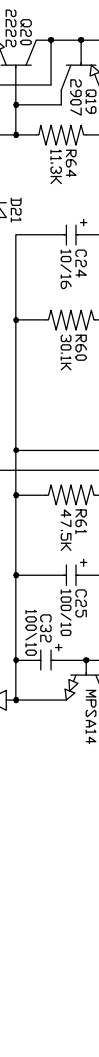
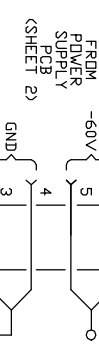

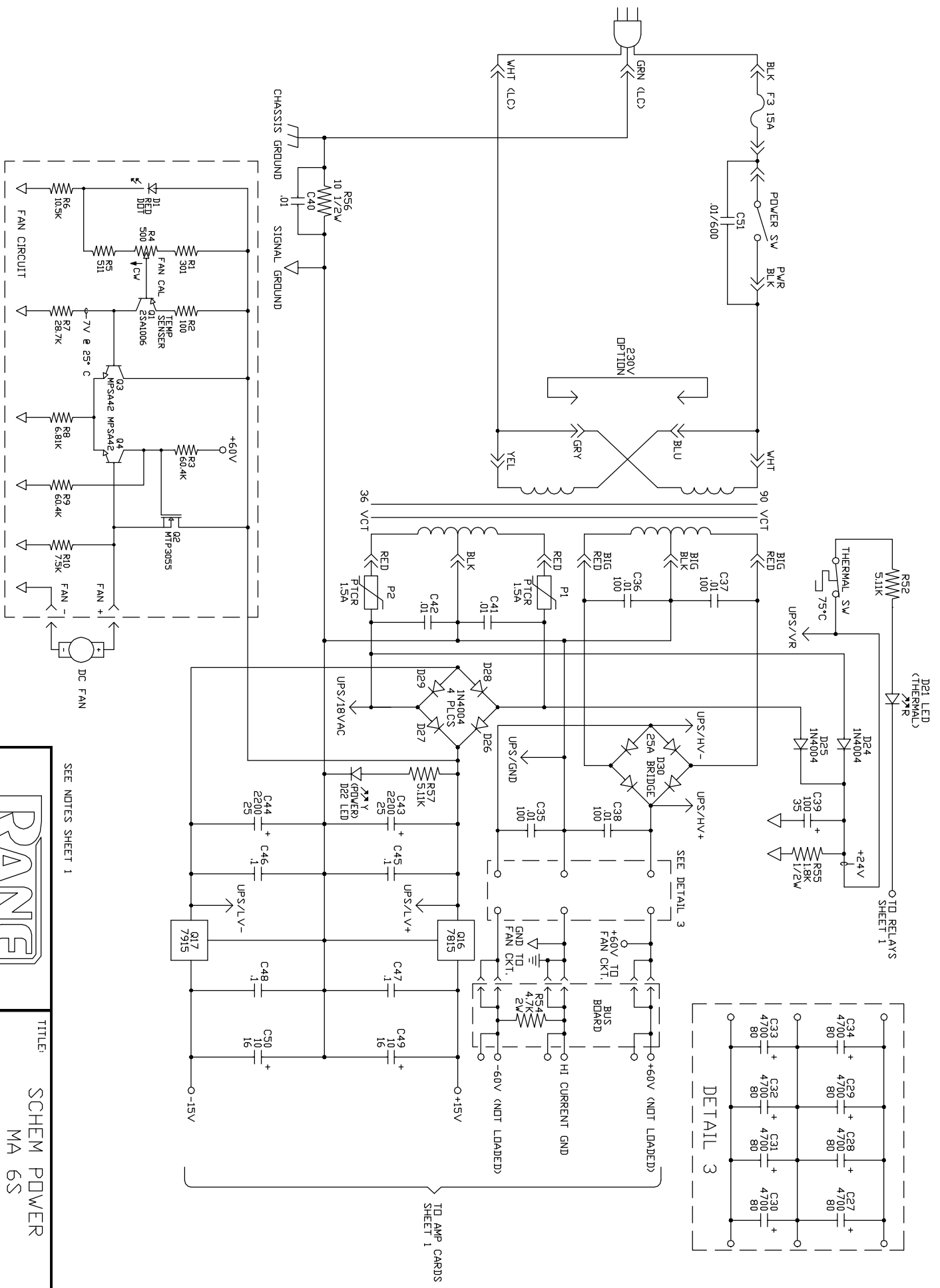

SEE NOTES SHEET 1

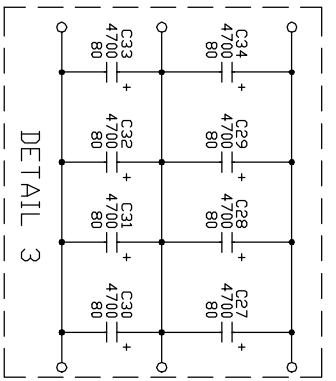

RANE

Corp. 10802 47th Avenue West, Mukilteo
 WA 98275-5098 (425) 355-6000

DDC. NO. 101550

TITLE: SCHEM POWER
 MA 6S